

# Life Cycle Assessment (LCA) of an Integrated Solar PV and Wind Power System in Vietnam

LE QUYEN LUU<sup>1,2\*</sup>, BINH VAN DOAN<sup>1</sup>, NINH QUANG NGUYEN<sup>1</sup>  
AND NAM HOAI NGUYEN<sup>1</sup>

<sup>1</sup>Institute of Energy Science, Vietnam Academy of Science and Technology, Vietnam

<sup>2</sup>Department of Engineering, University of Palermo, Italy

## Abstract

In Vietnam, energy generation accounts for more than half of the national greenhouse gas (GHG) emission. This sector has tremendous potential for emission reduction through the exploitation of renewable energy resources. This study examines the environmental impact of grid-connected solar and wind power in Vietnam, with a focus on GHG emissions. A life cycle assessment was conducted for these purposes. A case study of an integrated 50 kWp solar photovoltaics (PV) and 6 kW wind power model in the Central Highland of Vietnam was selected to illustrate the environmental impact of solar and wind power in Vietnam. The environmental inflows and outflows were quantified from raw material extraction for manufacturing components of the model, such as the panels, turbines, inverters and subsidiary components, to the end of life of the model. OpenLCA software was used for the calculation, with background data from publications and free LCA databases. The results obtained indicate that the life cycle GHG emissions are 20 gCO<sub>2e</sub>/kWh of solar PV, 3.7 gCO<sub>2e</sub>/kWh of wind power, and the total emission of the model during its 25-year lifetime is 38.28 tCO<sub>2e</sub>. If solar and wind power replace grid power, the lifetime emission reduction of the integrated solar and wind power model would be 1.8 thousand tCO<sub>2e</sub>.

Keywords: solar PV, wind power, LCA, GHG emissions, Vietnam

## 1. INTRODUCTION

The increasing emissions of anthropogenic greenhouse gas (GHG) requires immediate and strong actions. The adoption of renewable energy technologies is believed to tackle this problem. In Vietnam, the energy sector contributed 151.4 MtCO<sub>2e</sub> in 2013, accounting for 58% of the national GHG emissions with land use, land use change and forestry (LULUCF) [1]. In 2014, the emissions of this sector increased by 13% to 171.62 MtCO<sub>2e</sub>, accounting for 60% of the national GHG emissions with LULUCF [2]. The Vietnamese government identified a range of actions to mitigate the GHG emissions of the energy sector. By applying 17 mitigation actions on renewable energy

---

\*Corresponding author: luulequyen@gmail.com

Received: 11 Oct 2020 Accepted: 17 Oct 2020 Published: 30 Oct 2020

Journal of Asian Energy Studies (2020), Vol 4, 36-47, doi:10.24112/jaes.040005

and energy efficiency technology, the GHG emission reduction was expected to reach around 65.93 MtCO<sub>2</sub>e by 2030 [2].

Globally, many life cycle assessment (LCA) studies have been conducted to estimate and quantify GHG emissions of renewable energy technologies. In 2003, Goralczyk conducted an LCA on the renewable energy sector of Poland, to compare environmental impacts of renewable and conventional energy [3]. The technologies investigated included solar PV, wind turbine, hydropower, oil thermal, coal thermal and natural gas thermal power. It was estimated that the GHG emissions and waste generation of solar PV were the highest among renewable sources, at 29 kgCO<sub>2</sub> and 6.4 gCO<sub>2</sub>, but insignificant when compared to conventional energy sources [4].

Jungbluth et al. applied LCA to study the environmental impacts of twelve grid-connected solar PV at 3 kWp and 4 wind turbine systems from 30 kW to 800 kW in Switzerland [4]. With the Eco-indicator 99 (H, A) impact assessment, it was indicated that the highest environmental impacts originated from the average solar PV power, while the slanted roof, pc-Si power had the least environmental impact. Among the impact categories, most of the environmental impact was concentrated in fossil fuel consumption and respiratory effects. In terms of wind power, the GHG emissions of 800kW onshore and 2 MW offshore wind power were 11 g/kWh and 13 g/kWh respectively. Among all the impact categories studied, carcinogenic and respiratory effects were the highest impacts for the 2MW turbine. All impact categories of offshore turbines were higher than those of onshore turbines, except for land use effect [4].

Varun et al. reviewed existing LCAs on electricity generation technologies from renewable sources and identified that the GHG emissions of renewable power technologies were not totally non-existent, but insignificant, compared to fossil fuel-based technologies [5]. Specifically, the GHG emissions of solar PV and wind power were 53.4 – 250 gCO<sub>2</sub>/kWh and 9.7 to 123.7 gCO<sub>2</sub>/kWh respectively, while those of coal fired power were the highest among all types of energy generation technologies, at 975.3 gCO<sub>2</sub>/kWh [5].

In Asia, several LCAs studies have been conducted on the environmental impacts of solar PV and wind power. Hondo conducted a combined process-based and input output LCA on the Japanese power sector in base case (current situation of the power sector) and future case (taking into account technological improvements) [6]. The author identified that the GHG emissions of wind power were 29.5 gCO<sub>2</sub>/kWh in the base case and 20.3 gCO<sub>2</sub>/kWh in the future case. For solar PV, the GHG emissions were 53.4 gCO<sub>2</sub>/kWh in the base case and 42.9 and 26.0 gCO<sub>2</sub>/kWh in the future cases of a-Si and p-Si solar cells respectively [6].

An LCA study conducted on a small, grid-connected solar PV system in Singapore indicated that the life cycle GHG emission of solar PV is 217 gCO<sub>2</sub>/kWh [7]. In cases of technology improvement, change in the supporting structure and efficiency improvement of the solar PV module reduced the GHG emissions to 129 gCO<sub>2</sub>/kWh, 177 gCO<sub>2</sub>/kWh and 165 gCO<sub>2</sub>/kWh respectively. In this study, GHG emissions of CH<sub>4</sub> and N<sub>2</sub>O were ignored due to the uncertainty of the data on primary energy consumption in the background process [7].

Li et al. conducted an LCA on 33 wind farms with an installed capacity of 1.5MW in China [8]. Five major pollutant emissions including those of carbon dioxide (CO<sub>2</sub>), particulate matter (PM), carbon monoxide (CO), nitrogen oxide (NO<sub>x</sub>) and sulfur dioxide (SO<sub>2</sub>) were calculated and it was identified that the life cycle CO<sub>2</sub> emissions were the highest among different pollutants, at 31.32 gCO<sub>2</sub>/ kWh [8].

In Vietnam, to the best of the authors' knowledge, no other work has conducted an LCA on integrated solar PV and wind power. This paper will present a case study on an integrated model of 50 kWp solar PV and 6 kW wind power in the Central Highland of Vietnam.

## 2. MATERIALS AND METHODS

LCA quantifies the environmental and material input and output flows of a product system over its life cycle [ISO, 1997 cited in 9]. All inputs, emissions and waste are accounted over all stages relevant to the product system, from raw material exploitation, processing, production, consumption of product and service, to transportation and waste treatment. LCA is an effective and systematic methodology to assess the environmental impacts of a product system [9]. This study followed the international standard on LCA, including ISO 14040:2006 [10] and ISO 14044:2006 [11].

There are two common approaches for conducting an LCA: process-based and input-output-based LCA [12]. In the process-based approach, a product/ service is analyzed on its inputs (raw materials and energy) and outputs (emissions and waste) in different stages over its life cycle. For example, in the generation of bio-power, the common processes include energy crop plantation, preparation of biomass materials, transportation of biomass materials to power plants and bio-power generation. Each process requires inputs such as seeds, fertilizers, water during the energy crop plantation, fuel, oil and gasoline during the transportation of biomass materials and outputs such as waste and waste water during the energy crop plantation, emissions to air during the preparation of biomass materials, transportation of biomass material and bio-power generation.

Another approach to conduct an LCA is based on the input-output model, where flows of product/ service (outputs of one industry) are consumed by another industry (used as input in another industry). These flows of inputs and outputs are presented in the form of a matrix, in which each row and column represents an industry. The interactions between rows and columns determine the economic value of one industry's outputs (in rows) and requirement of one industry's inputs (in columns). These transactions among industries are converted into monetary value. As the conventional input-output model focuses on describing economic activities among industries, in order to be eligible for LCA, the model needs to be supplemented with the environmental columns, which is known as the environmental extended input output (EEIO) model. The row value of these environmental columns represents the environmental outflows of these industries. At the same time, these outflows are inflows of the "environment" industries.

All interactions and emissions of all industries are described in the EEIO model; therefore, the system boundary of the investigated product system is large. However, in contrast to its comprehensiveness, the details of each product in one industry are not clearly described. As a result, the input output-based LCA is suitable for assessing environmental impacts of one industry or one economic sector with several products, for example, the power generation sector with different types of technologies, such as coal thermal power, gas turbine power, hydropower, wind power, solar power and so on. In order to clearly describe the life cycle environmental impacts of a specific product, for example solar PV or wind power, the process-based LCA would be more suitable.

The investigated product system is an integrated 50 kWp solar PV and 6 kW wind power model, being installed in the Central Highland of Vietnam. As the product system is specific, without being upscaled to other regions or over the country, and the relative amount of power generation is small compared to the total national power generation, the process-based approach will be applied.

In order to conduct an LCA on a simple product system, the calculation can be performed manually, with the support of Excel sheets. However, for a complex product system, the dataset will be large, making it difficult to calculate on Excel sheets. Several LCA software are available which support the calculation of LCA for complex product systems, such as SimaPro of PRÉ

Consultants [13], GaBi Software of PE International [14] and OpenLCA of Greendelta [15]. SimaPro and Gabi have a built-in life cycle inventory database; therefore, the burden of data collection will be reduced and the users need not enter all input data. These softwares require an annual subscription fee.

The study used OpenLCA for the life cycle impact calculations and assessment of the integrated model. OpenLCA has the advantage of an open source software, which can be adjusted according to the users' preference. This software is highly suitable for calculating and assessing the life cycle impact under the financial constraints. However, OpenLCA requires users to collect the technical data as well as environmental inventory database. The specific database used in the study will be presented in the following part.

### 3. DEFINITION OF GOAL AND SCOPE

This study aims to provide provincial and regional authorities information on environmental benefits and impacts of integrated solar PV and wind power in Vietnam, using the 50 kWp solar PV and 6 kW wind power model in the Central Highland in Vietnam as a case study. The product system of an integrated solar PV and wind power model will generate renewable power. All the raw material, energy and water consumptions, and emissions to air, water and soil are accounted for the functional unit of 1 kWh of renewable power.

The whole life cycle of the integrated solar PV and wind power model will be covered in the study, from manufacturing of components of the two modules, installing and constructing the modules, operating the model and its end of life (Figure 1). It is assumed that impacts from infrastructure and subsidiary systems are insignificant and are thus excluded from the system boundary of the investigated product system.

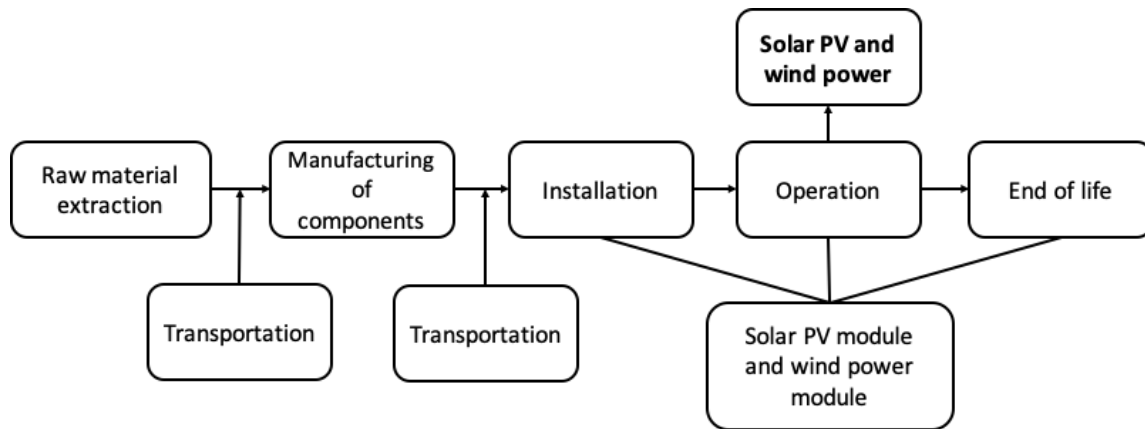

**Figure 1:** System boundary of the integrated solar PV and wind power model

In terms of data collection, processes that directly relate to the module are accounted by the properties of the actual module being installed in the Central Highland of Vietnam. The data of these processes are taken from the technical specification of the modules and information/document provided by the manufacturer and calculated by the authors. Background processes are accounted by reviewing solar PV and wind power LCA reports and some free LCA databases [16–19].

The selected impact assessment methodologies are Recipe and IPCC. Although there are several other such methodologies, such as CML, IPCC, Eco indicator and TRACI, they have

various applications. CML and Eco Indicator methodology focus on environmental impacts, while TRACI focuses on the human health impact. Recipe is the most common impact assessment methodology for energy projects and was hence selected for this study. Besides, the paper used IPCC methodology, which focuses on climate change impacts. The results obtained with IPCC methodology are used for comparison with those obtained with Recipe.

#### 4. DESCRIPTION OF TECHNOLOGIES

The integrated 50 kW solar PV and 6 kW wind power model was installed in the high-tech agriculture area of the Vietnam Academy of Science and Technology (VAST) in the Central Highland of Vietnam in 2019. The list of components of the integrated solar PV and wind power model is furnished in Table 1. Configuration of the two modules has been presented in Figures 2 and 3.

The solar PV module includes two blocks of 45.5 kWp and 4.4 kWp. The 45.5 kWp block is a fixed, roof-mounted module, including 123 single crystalline solar panels, each with a capacity of 370 Wp. This block is connected in series to increase the voltage to match the working voltage of the grid-connected inverter. After being stably connected to the solar system, the inverter will be connected to the local three-phase power grid. Power from the solar systems is direct current, and is converted into alternating current by the DC/AC grid connected inverter. The voltage and frequency of the power is suitable for connecting to the industrial power grid. Power generated from the solar system will be used for internal load of VAST's high-tech agriculture area, in replacement of power from the national grid. Any excess power will be transmitted to the local power grid.

The wind power module includes three small, vertical wind turbines, with a capacity of 2kW each. Power from these turbines will be connected to the battery system (8x200Ah) through the load controller. As the wind speed in the installed area is quite low and unstable during some months of the year, the wind power module will be connected to the 4.4 kWp solar PV block. The DC/AC hybrid inverter will be used to connect the wind turbines, 4.4 kWp solar PV block, grid power and loads of the VAST's high-tech agriculture area. The DC/AC hybrid inverter can charge the battery system from the solar PV block or from the grid power. When the battery system is fully charged, the power from the solar PV block will be transmitted to the AC local grid. When the grid power is disrupted, the battery system will provide power for the continuous operation of loads of VAST's high-tech agriculture area.

The total annual power generation of the model is 80,835 kWh. The power generation quantum of the solar PV module is calculated based on the solar radiation potential of the installation site, with PVsyst software. The total solar PV power generation output is 82,706 kWh annually. Table 2 specifies the annual power generation output of the model. The amount of power generation of the wind power module is calculated based on the wind speed of the installation site, with RETSCREEN software. The total wind power generation output is 5,256 kWh annually.

The life cycle of the integrated model includes the life cycle of the solar PV module and wind power module. The solar PV module life cycle includes processes of manufacturing of solar PV panel (mg-silicon, mono-crystalline silicon, wafer, metallization past, photovoltaics cell, solar panel, assembly of components), manufacturing of inverters and other components, installation of panels, inverters and other components, operation and the end of life of the module. These processes include the transportation of panel components to the panel-manufacturing factory, transportation of panels, inverters and other components to the installation site and transportation of the de-commissioned equipment to the recycling site, at the end of the module's life cycle. The solar PV module life cycle excludes machines used for the manufacture of PV panels or mounted

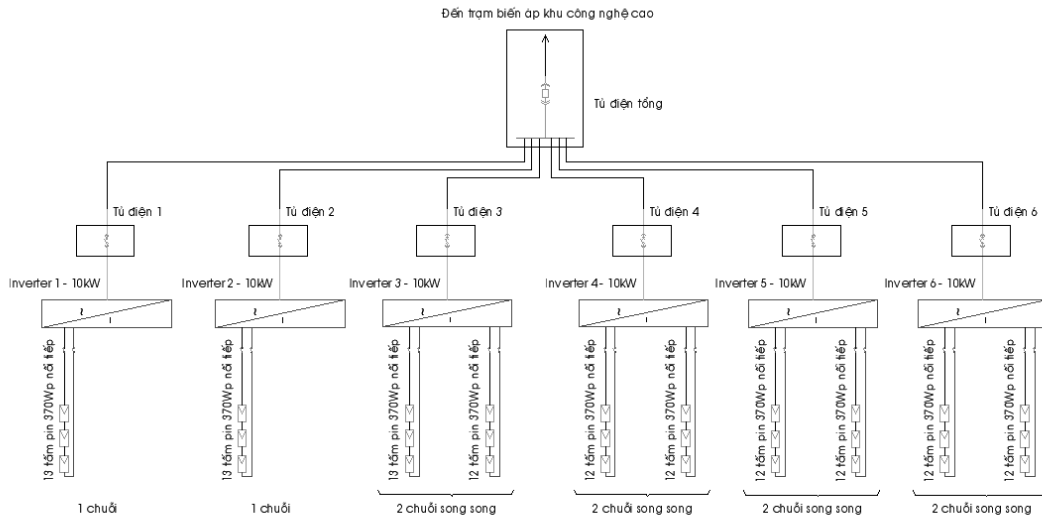

Figure 2: Configuration of solar PV module

Table 1: Components of the investigated model

	Number	Capacity
Solar PV cell	135	370 Wp
3-phase inverter	6	10 kW
Mounting framework	1	
Electric power station	1	
other subsidiary systems	1	Connecting box, cables, ground connecting system
Wind turbine	3	2kW
Load controller	3	
Battery	8	200 Ah
Hybrid inverter	1	4.6 kW

frame.

The wind power module life cycle includes processes of manufacturing of wind turbines, wind tower, nacelle, base/ foundation, cables, inverters and other components, construction and installation of turbines, inverters and other components, operation and end of life of the module. These processes include the transportation of turbine components to the turbine manufacturing factory, transportation of turbines, inverters and other components to the installation site and transportation of the de-commissioned equipment to the recycling site at the end of the module' life. The wind power module life cycle excludes machines used for the manufacture of tower, blades or cables.

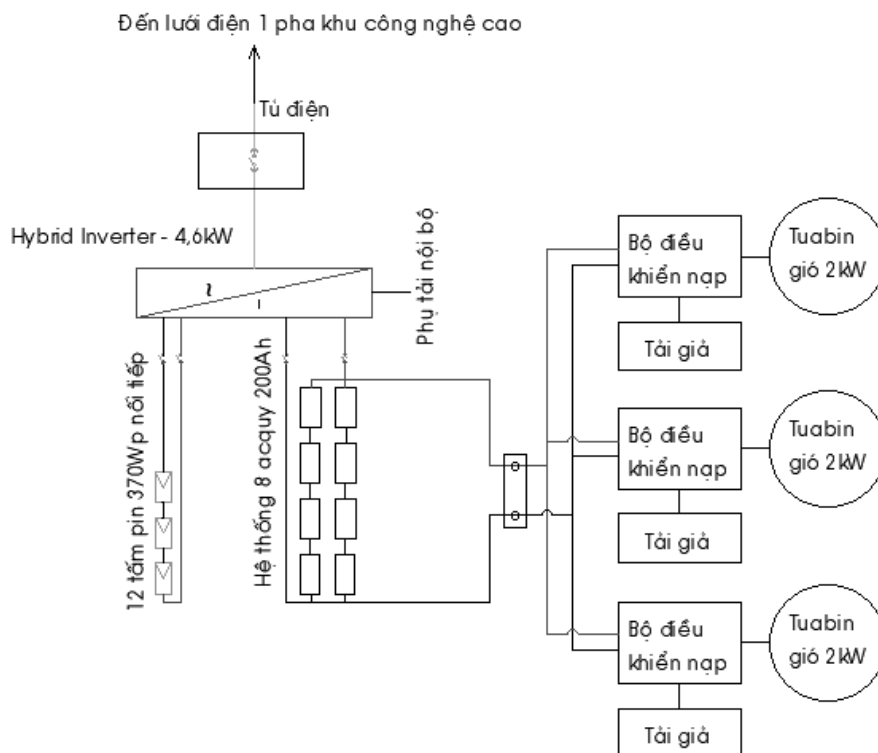

Figure 3: Configuration of wind power module

Table 2: Annual power generation output of the solar PV module

	Gl. Horiz kWh/m <sup>2</sup> .day	Coll. Plane kWh/m <sup>2</sup> .day	System output kWh/day	System output kWh
Jan	4.24	4.68	192.6	5970
Feb	5.20	5.59	230.2	6444
Mar	5.37	5.56	229.1	7102
Apr	5.69	5.64	232.4	6973
May	5.66	5.45	224.3	6953
Jun	5.59	5.28	217.3	6520
Jul	5.83	5.54	228.2	7073
Aug	5.47	5.35	220.3	6831
Sep	4.94	5.02	206.6	6199
Oct	4.32	4.51	185.8	5760
Nov	3.69	4.03	166.0	4981
Dec	3.38	3.74	154.0	4773
Year	4.95	5.03	207.1	75579

## 5. RESULTS AND DISCUSSION

The life cycle inventory results of the integrated model indicated that most of the inputs for renewable power consisted of water usage, resource consumption from the ground and consumption of fossil fuel (Table 3). Water was used mainly during the operation of turbines in the background process. Fossil fuel consumption included consumption of coal, crude oil and natural gas. Land resource consumption included gravel, canxi carbonate during the construction and installation of the model. Consumption of metals and other minerals (excluding coal) was insignificant. Outputs of manufacturing and operating the model included land use impact, impact on water, emissions of radon-222, hydrogen-3, radioactive substances and waste heat. Land use mostly concerned the process of disposal of radioactive waste of solar panels. Similarly, the emissions of radon-222 and radioactive substances came from solar PV production processes. Impacts on water resources included hydrogen-3 and wastewater of the cooling processes (Table 4).

**Table 3:** *Some main inputs of the integrated model*

Inputs	Category	Sub category	Unit	Amount
Water, turbine use, unspecified natural origin	Re-source	Water	m3	0.1586
Energy, potential (in hydropower reservoir), converted	Re-source	Water	kWh	0.02790
Gravel	Re-source	Ground	kg	0.0216
Energy, gross calorific value, in biomass	Re-source	Biotic	kWh	0.007328
Calcium carbonate	Re-source	Ground	kg	0.003668
Coal, hard, unspecified	Re-source	Ground	kg	0.003487
Coal, brown	Re-source	Ground	kg	0.003414
Energy, kinetic (in wind), converted	Re-source	Air	kWh	0.00336
Oil, crude	Re-source	Ground	kg	0.002503
Gas, natural	Re-source	Ground	m3	0.002451

The life cycle impact assessment results indicated that renewable power generated by the integrated model has a minor impact on the ecosystem and human health. Most of the impacts originate from resource consumption. Table 5 presents the life cycle impacts of power generated by the integrated model with Recipe Endpoint H.

Calculation of climate change impact by two different impact assessment methods, including Recipe Midpoint H and IPCC2013, demonstrated that life cycle GHG emissions of solar PV and wind power are 0.02 kgCO<sub>2</sub>e/kWh and 3.7 gCO<sub>2</sub>e/kWh respectively, which constitute a total of 20 gCO<sub>2</sub>e/kWh. The majority of renewable electricity emissions come from solar modules, accounting for 85% of the total emissions. Wind power module emissions are small, at about



**Table 4:** *Some main outputs of the integrated model*

Outputs	Category	Sub category	Unit	Amount
Volume occupied, final repository for radioactive waste	Resource	Land	m3	446
Volume occupied, final repository for low-active radioactive waste	Resource	Land	m3	406
Water, cooling, unspecified natural origin	Resource	Water	m3	390.995
Radon-222	Emission to air	Low population, long term	kBq	6.027
Noble gases, radioactive, unspecified	Emission to air	Low population	kBq	3.352
Radon-222	Emission to air	Low population	kBq	0.1438
Hydrogen-3, Tritium	Emission to water	Ocean	kBq	0.1349
Heat, waste	Emission to air	High population	kWh	0.03489
Heat, waste	Emission to air	Unspecified	kWh	0.02680
Hydrogen-3, Tritium	Waste water	River	kBq	0.01371

**Table 5:** *Life cycle impacts of the integrated solar PV and wind power models*

Impacts	Results
Human health (DALYs)	0.00086
Ecosystem (species/ year)	2.09E-6
Resource consumption (USD2013)	0.0021

15-16% of the total emissions. There is a small difference in emissions of the wind power module when calculated by the Recipe indicator and IPCC2013, at 3,818E-3kgCO<sub>2</sub>e with the Recipe indicator and 3,772E-3 kgCO<sub>2</sub>e with the IPCC2013 indicator. This difference accounts for only about 1% of the module emissions, and is negligible. The results of climate change impact of renewable electricity are shown in Figures 4 and 5.

According to the calculation of the Department of Climate Change, the emission factor of Vietnam electricity grid is 0.913 kgCO<sub>2</sub>e/kWh (Document No. 263/BDKH of DCC dated on 12 March 2020). This emission factor is much higher than the life cycle emission of the investigated integrated model, at 20 gCO<sub>2</sub>e/kWh solar PV and 3.7 gCO<sub>2</sub>e/kWh wind power. The annual electricity generation of the module is estimated at 75,579 kWh for solar PV module and 5,256 kWh for wind power module. When the grid power is replaced by solar power and wind power, the GHG emission reductions of the integrated module for 25 years of operation are around 1.8 thousand tCO<sub>2</sub>e (Table 6).

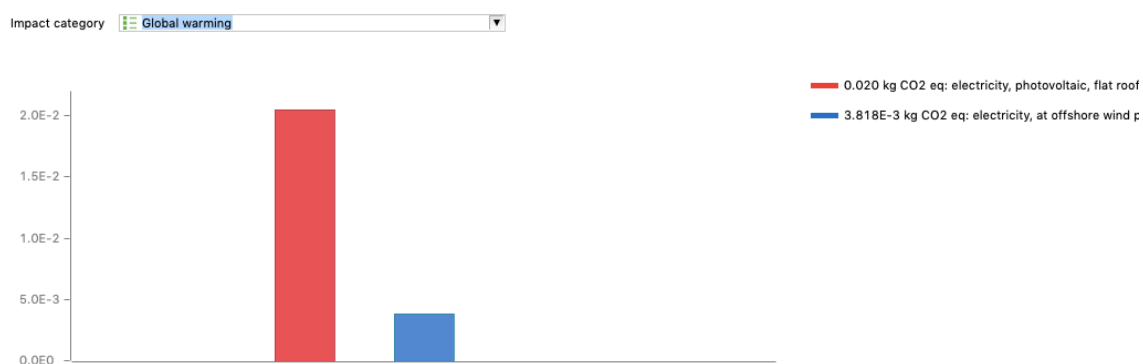

Figure 4: Global warming potential of the integrated model with Recipe



Figure 5: Global warming potential of the integrated model with IPCC2013

Table 6: Emission of the studied integrated model, compared to on-grid electricity power

	Electricity generation (kWh/year)	Life cycle GHG emission factor (kgCO2e/kWh)	Life-time (year)	Total GHG emission (kgCO2e)
Solar PV module	75,579	0.02	25 year	37,789
Wind power module	5,256	3.772E-3	25 year	495
On-grid electricity	80,835	0.913	25 year	1,845,058

\*The on-grid electricity emission was calculated based on the emission factor for 2019 on-grid electricity of the Department of Climate Change [20].

## 6. CONCLUSIONS

The renewable power generated by the integrated model of 50kWp solar power and 6kW wind power has minor environmental impact over its life cycle. Among the environmental impacts,

those on human health and the ecosystem are almost negligible. The renewable power generated by the integrated model causes a small impact on resource consumption over its life cycle. Besides, the GHG emission impacts of the model are also relatively small. During its 25 years of operation, the GHG emission reduction of the model would be about 1.8 thousand tCO<sub>2e</sub>, if it were replaced for on-grid power in Vietnam.

**Acknowledgement:** The authors extend the acknowledgement to the Institute of Energy Science – Vietnam Academy of Science and Technology for providing fund and the Department of Engineering – University of Palermo for creating favor during the study of this work. The paper is conducted as a subsidiary component of the research project “Research on completing the technology, constructing and transferring the model of exploiting and proper using solar and wind energy for production and daily living in Central Highland”. Code TN17/C03.

## REFERENCES

- [1] Vietnam Ministry of Natural Resources and Environment. *The Second Biennial Updated Report of Vietnam to the United Nations Framework Convention on Climate Change*. Vietnam Publishing House of Natural Resources, Environment and Cartography, 2017.
- [2] Vietnam Ministry of Natural Resources and Environment. *The Third Biennial Updated Report of Vietnam to the United Nations Framework Convention on Climate Change*. Vietnam Publishing House of Natural Resources, Environment and Cartography, 2019.
- [3] Góralczyk M. Life-cycle assessment in the renewable energy sector. *Applied Energy* 2003;75:205-211.
- [4] Jungbluth N, Bauer C, Dones R, Frischknecht R. Life cycle assessment for emerging technologies: case studies for photovoltaic and wind power. *The International Journal of Life Cycle Assessment* 2005;10:24-34.
- [5] Bhat IK, Prakash R. LCA of renewable energy for electricity generation systems—a review. *Renewable and Sustainable Energy Reviews*. 2009;13:1067-1073.
- [6] Hondo H. Life cycle GHG emission analysis of power generation systems: Japanese case. *Energy* 2005;30:2042-2056.
- [7] Kannan R, Leong KC, Osman R, Ho HK, Tso CP. Life cycle assessment study of solar PV systems: An example of a 2.7 kWp distributed solar PV system in Singapore. *Solar Energy*. 2006;80:555-563.
- [8] Li H, Jiang HD, Dong KY, Wei YM, Liao H. A comparative analysis of the life cycle environmental emissions from wind and coal power: Evidence from China. *Journal of Cleaner Production* 2020;248:119192.
- [9] Horne RE. Life cycle assessment: origins, principles and context. In: Horne RE, Grant T, Vergheze K (eds). *Life Cycle Assessment - Principles, Practice and Prospects*. CSIRO Publishing, Collingwood, 2009, p. 1-8.
- [10] International Organization for Standardization. *Environmental Management: Life Cycle Assessment: Principles and Framework, ISO 14040:2006*. International Organization for Standardization, Geneva, 2006.
- [11] International Organization for Standardization. *Environmental Management: Life Cycle Assessment: Requirements and Guidelines, ISO 14044:2006*. International Organization for Standardization, Geneva, 2006.
- [12] Bjorn A, Owsianiak M, Molin C, Hauschild MZ. LCA history. In Hauschild MZ, Rosenbaum RK, Olsen SI (eds). *Life Cycle Assessment*. Springer, Cham, 2018, p. 17-30.
- [13] SimaPro. <https://simapro.com/about/>

- [14] GaBi. <http://www.gabi-software.com/international/software/>
- [15] Open LCA. <http://www.openlca.org/openlca/>
- [16] ELCD database. <https://nexus.openlca.org/database/ELCD>
- [17] Jungbluth N, Stucki M, Flury K, Frischknecht R, Büsser S. *Life Cycle Inventories of Photovoltaics*. ESU-Services, Uster, 2012.
- [18] Frischknecht R, Heath G, Raugei M, Sinha P, de Wild-Scholten M. *Methodology Guidelines on Life Cycle Assessment of Photovoltaic Electricity: 3rd Edition*. National Renewable Energy Lab, Golden, 2016.
- [19] NEEDS database. <https://nexus.openlca.org/database/NEEDS>
- [20] Department of Climate Change. *Document No. 263/BDKH of DCC*. Vietnam Ministry of Natural Resources and Environment, 2020.



© The Author(s) 2020. This article is published under a Creative Commons Attribution (CC-BY) 4.0 International License.